



Welcome

PFC Power Factor Controller BR604

Product Presentation

Main features

- 4 switching relay-outputs
- Four-quadrant operation (e.g. for generator set)
- Display of various grid parameters (cosPhi, V, I, Q, P, S...)
- Storage of maximum line-parameter values
- Manual / automatic operation with the option of programming of fixed stages and skipping individual outputs
- No-voltage (short term voltage interruption) turn-off
- Ease of use by complete menu-guided operation and display
- Intelligent control behaviour

BR604 Front side



Operating mode

- Automatic
- Programming
- Manual operation
- Service
- Expert mode



Enter / OK
Confirm and
store values



Increase
selected
parameter



Reduce
selected
parameter



BR604 Rear side

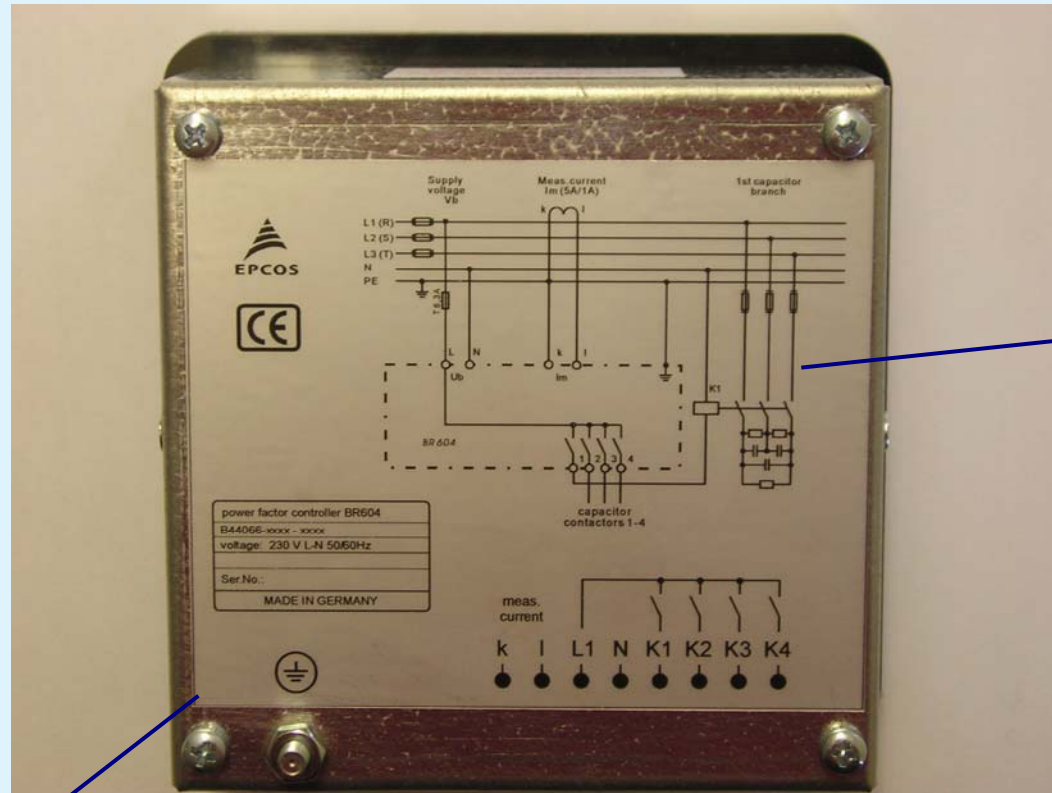

BR604 Multifunctional display

User friendly LCD Display

- 2 x 16 characters allows plain language guiding
- Display easy readable due to 5 x 7 dots character matrix
- Contrast of LCD display adjustable for optimum perception
- English and German language

BR604 Multifunctional display

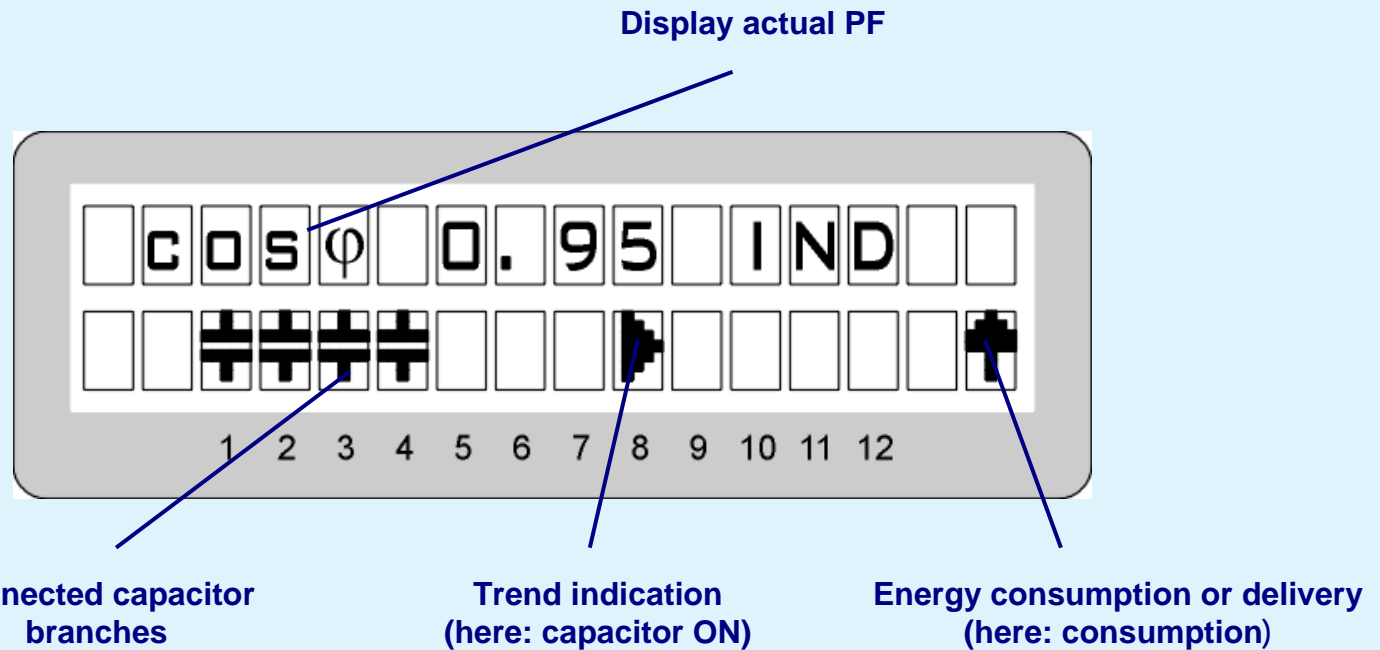

▶ Switching capacitors on

◀ Switching capacitors off

The arrow indicating additional capacitors to be switched in is always after the max. number of capacitors.

> An open arrow indicates a pending discharge cycle, means a discharge delay time is ongoing before the step is reconnected again.

BR604 Connection diagram

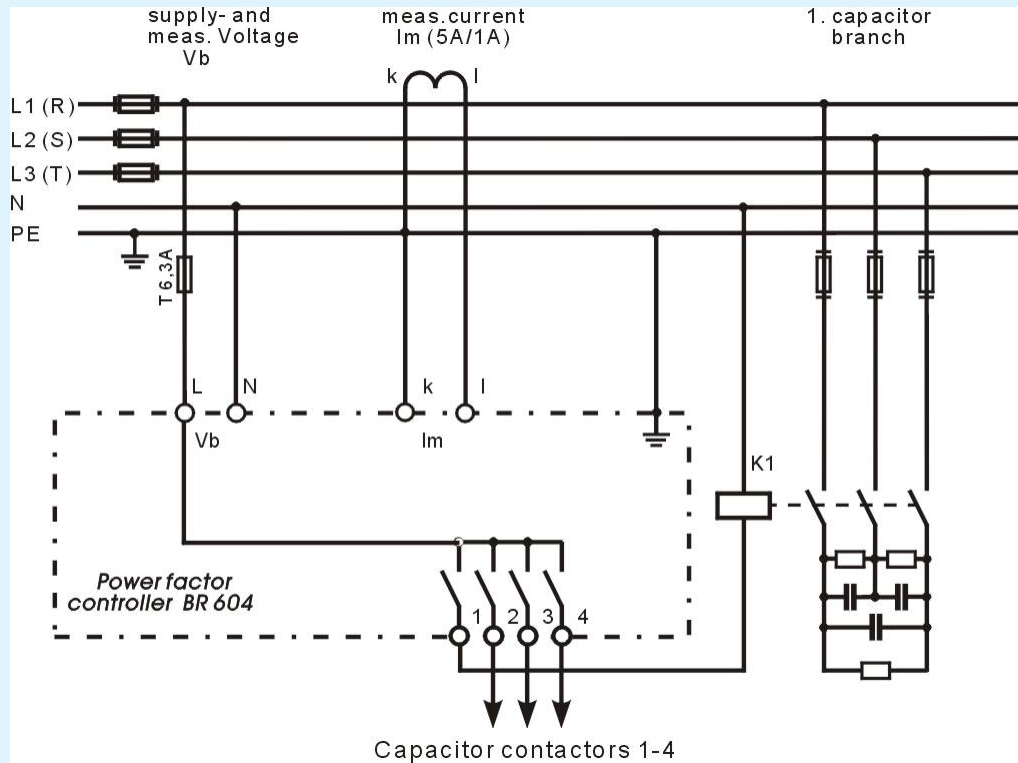

Structured menu dialog

Clearly structured menu dialog, for easy...

...installation

...operation

...failure analysis

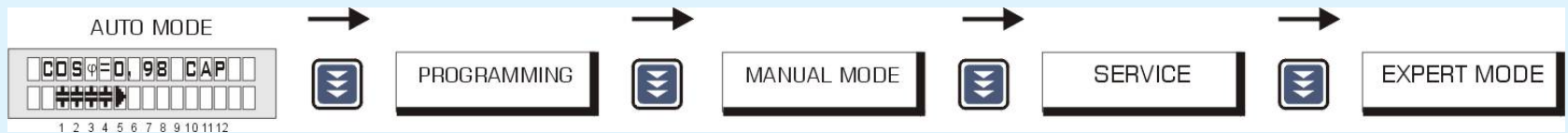

BR604 Customer benefits

Plain language menu

- User friendly – human machine interface
- Menu and programming in plain language
- Easy understandable terms
- One main menu for programming
- Clearly arranged menu structure

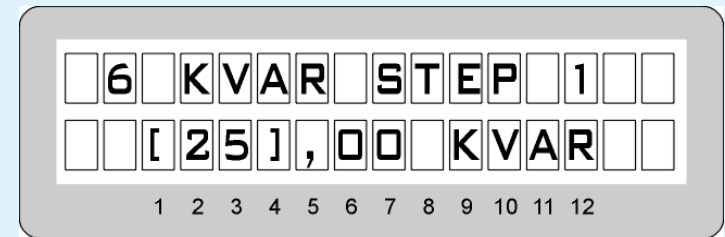

BR604 Customer benefits

Storing of important system parameters

- Max. voltage
- Max. reactive power
- Max. active power
- Max. apparent power

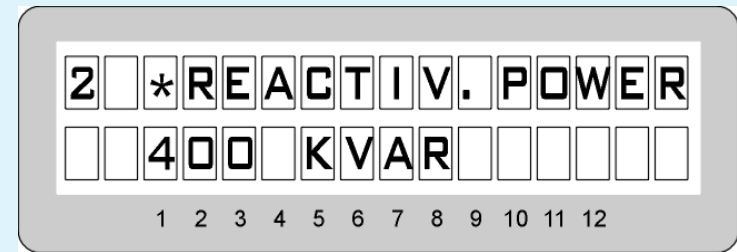

BR604 Customer benefits

Three different control modes

1. Serial connection – LIFO
2. Circular mode – FIFO
3. Intelligent mode

BR604 Customer benefits

Manual operation

All capacitors can individually be switched in manually.

Individual steps can be programmed as fixed stages.

Easy identification of defect contactors

- Useful for low load or installation period
- Useful for maintenance

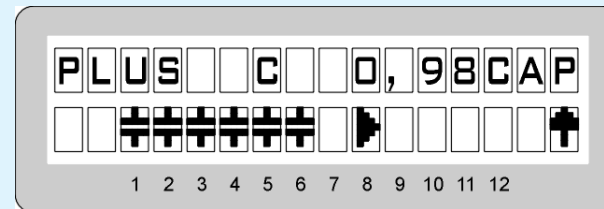
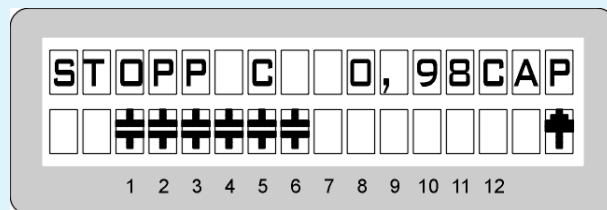

BR604 Generator operation

- 4 quadrant operation possible
- Usage for consumption and supply of energy
(e. g. water power plant with generator operation)

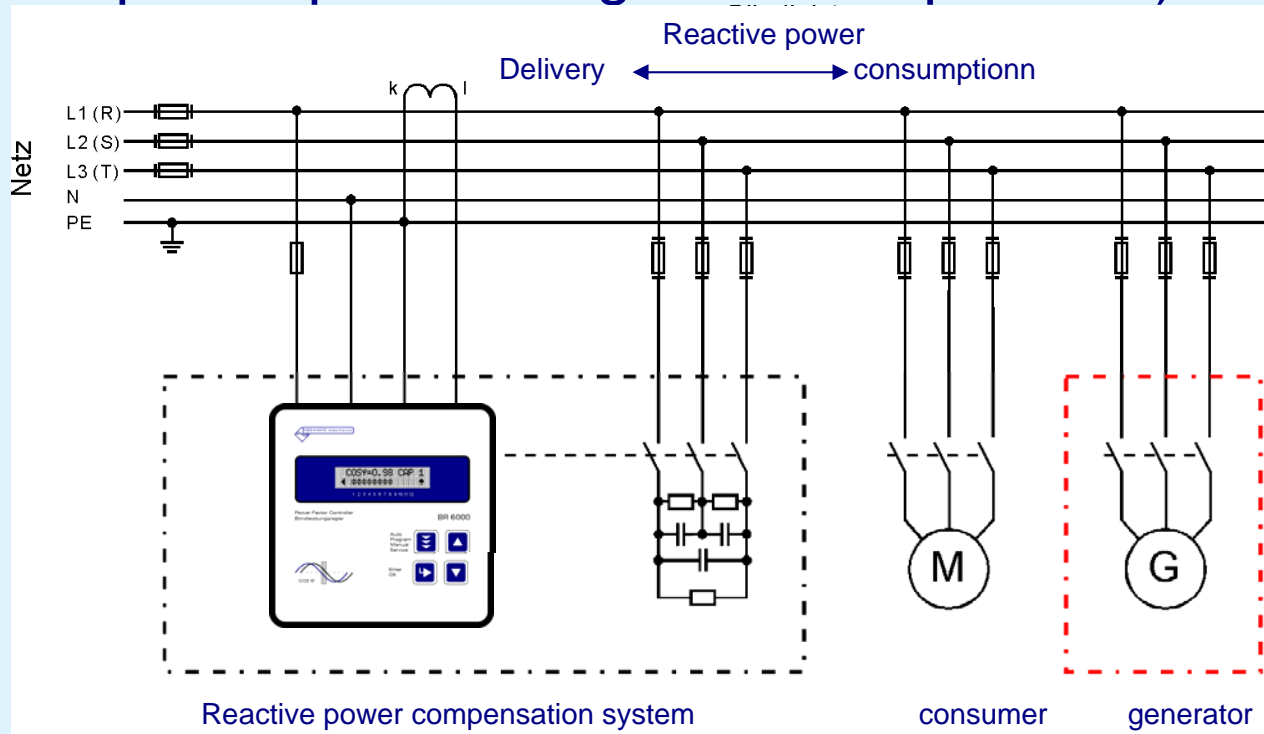

BR604 Preset control series

Nr.	Control series	Circular switching
1	1 : 1 : 1 : 1	Possible
2	1 : 2 : 2 : 2	Possible
3	1 : 2 : 2 : 3	Possible
4	1 : 2 : 2 : 4	Possible
5	1 : 2 : 2 : 5	Possible
6	1 : 2 : 2 : 6	Possible
7	1 : 2 : 3 : 3	Possible
8	1 : 2 : 3 : 4	Possible
9	1 : 2 : 3 : 5	Possible
10	1 : 2 : 3 : 6	Possible
11	1 : 2 : 3 : 7	Possible
12	1 : 2 : 4 : 4	Possible
13	1 : 2 : 4 : 5	Possible
14	1 : 2 : 4 : 6	Possible
15	1 : 2 : 4 : 7	Possible
16	1 : 2 : 4 : 8	Possible
17	1 : 1 : 2 : 2	Possible
18	1 : 1 : 2 : 3	Possible
19	1 : 1 : 2 : 4	Possible
20	1 : 1 : 2 : 5	Possible
21	1 : 1 : 1 : 2	Possible
22	1 : 1 : 1 : 3	Possible
23	1 : 1 : 1 : 4	Possible

BR604 Application

Sum current transformer

Connecting BR604 via a sum current transformer, the total transformation ratio has to be programmed:

$$(1000 + 1000) / 1 = 2000$$

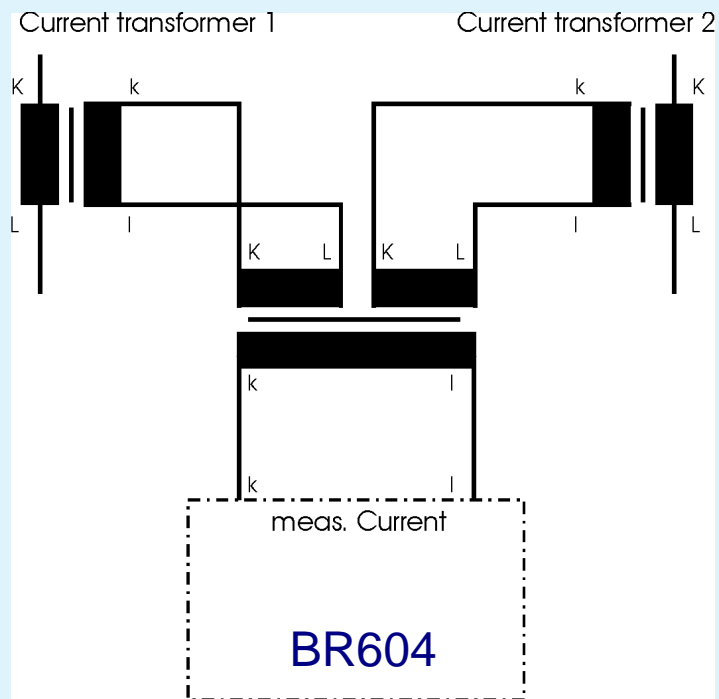

BR604 Technical data (1)

Outputs:	4
Switching power of relay:	250VAC, 1000W
Number of outputs:	programmable
Display:	graphic display 2 x 16 characters
Number of control series:	23
Control principle:	sequential-, loop connection, self optimized switching response
Supply and measuring voltage:	230VAC, 50/60 Hz
Measuring current:	X : 5/1 A
Sensitivity:	50 mA / 10 mA
Target cos Phi:	0.8 ind. to 0.8 cap.

BR604 Technical data (2)

Connecting time:	selectable from 1...255 sec.
Disconnecting time:	selectable from 1...255 sec.
Discharge time:	selectable from 1...255 sec.
Fixed stages / skipped stages:	programmable
No-voltage trigger:	standard
Display of grid parameters:	PF, V, I, Q, P, S
storage of maximum values:	V, Q, P, S
Housing:	switchboard integrated
Dimensions:	100 x 100 x 40mm
Weight:	0.5 kg
Operating temperature:	-10 to +60 °C
Protection type to DIN 40 050:	front IP 54 rear IP 20