



**Welcome**

# PFC Power Factor Controller BR6000

Product Presentation

# BR6000 Main features

- **6 or 12 switching outputs with a relay or transistor output**
- **Four-quadrant operation (e.g. for generator set)**
- **Display of various grid parameters ( V, I, F, Q, P, S...)**
- **Storage of maximum line-parameter and switching-operation values**
- **Manual/automatic operation with the option of programming of fixed stages and skipping individual outputs**
- **No-voltage (short term voltage interruption) turn-off**
- **Various alarm messages**
- **Complete menu-guided operation and display for highest user friendliness**
- **Intelligent control behaviour**



# BR6000 Front side

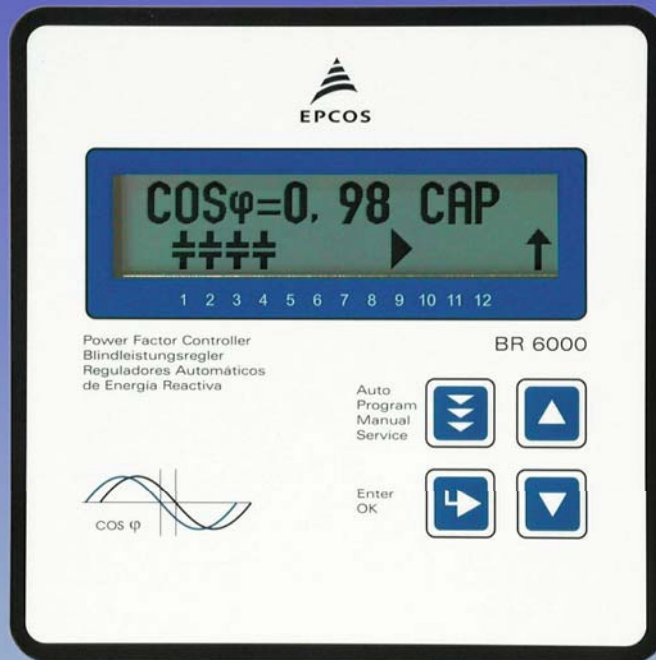

Operating mode

- Automatic
- Programming
- Manual operation
- Service
- Expert mode



Enter / OK  
Confirm and  
store values



Increase  
selected  
parameter



Reduce  
selected  
parameter



# BR6000 Rear side

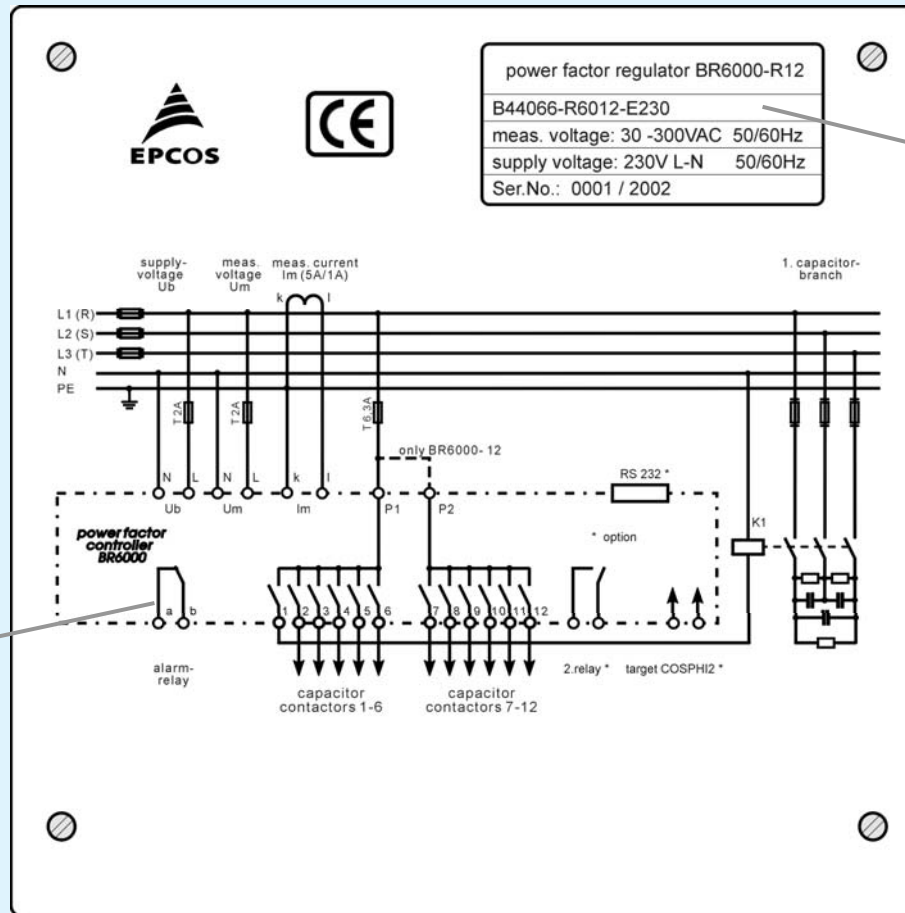

Wiring diagram

- Rating plate:
- Ordering code
  - Measuring voltage
  - Supply voltage
  - Serial number

# BR6000 Multifunctional display

## User friendly illuminated LCD Display

- 2 x 16 characters allow plain language guiding
- Display easy readable due to 5 x 7 dots character matrix
- Display back light ensures readability even in non well illuminated switch gear rooms
- Contrast of LCD display adjustable for optimum perception
- Standard 7 languages ( Czech, Dutch, English, German, Polish, Russian, Spanish )

# BR6000 Multifunctional display

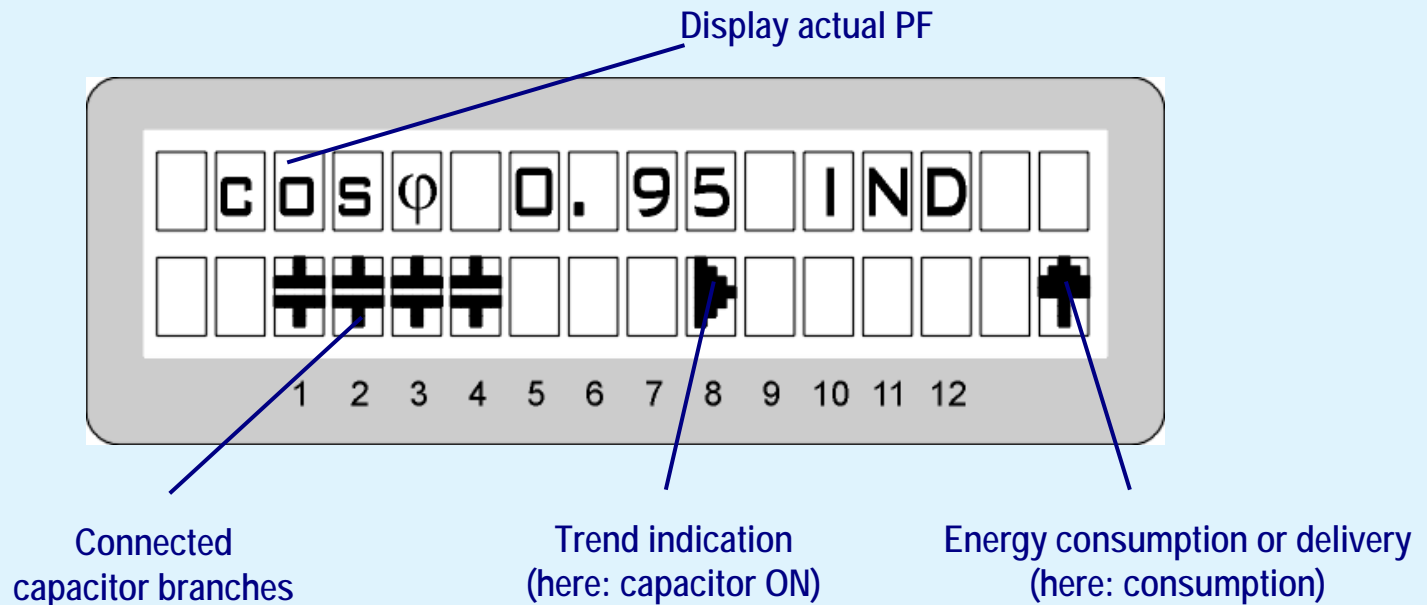

The control trend indication is signified by means of a closed arrow:

- ▶ Switching capacitors on
- ◀ Switching capacitors off

The arrow indicating additional capacitors to be switched in is always after the max. number of capacitors.

- An open arrow indicates a pending discharge cycle, means a discharge delay time is ongoing before the step is reconnected again.

# BR6000 Multifunctional display

## Display of actual power factor & kvar/steps

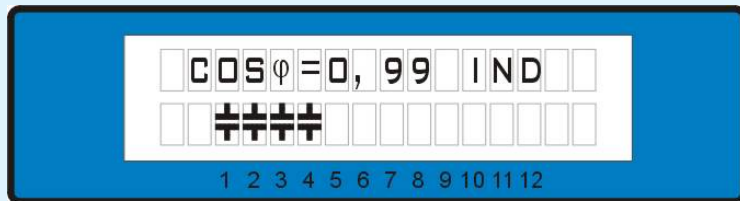

- Display as capacitor symbol (standard)

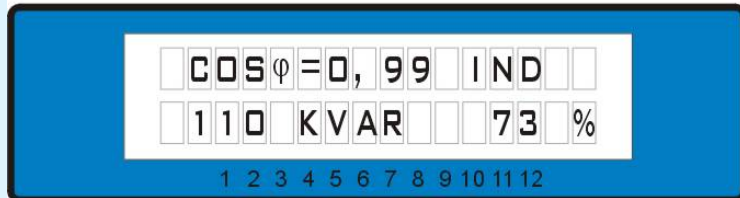

- Display of actually switched capacitor output in kvar and in % of complete system output.

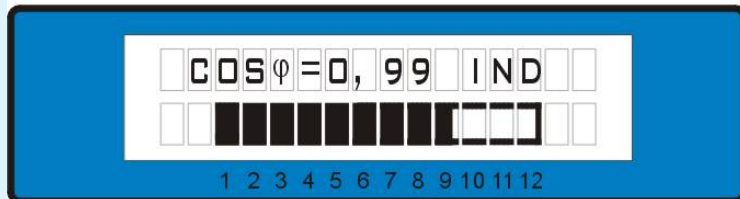

- Actual capacitor output as bar code display.

# BR6000 Connection diagram

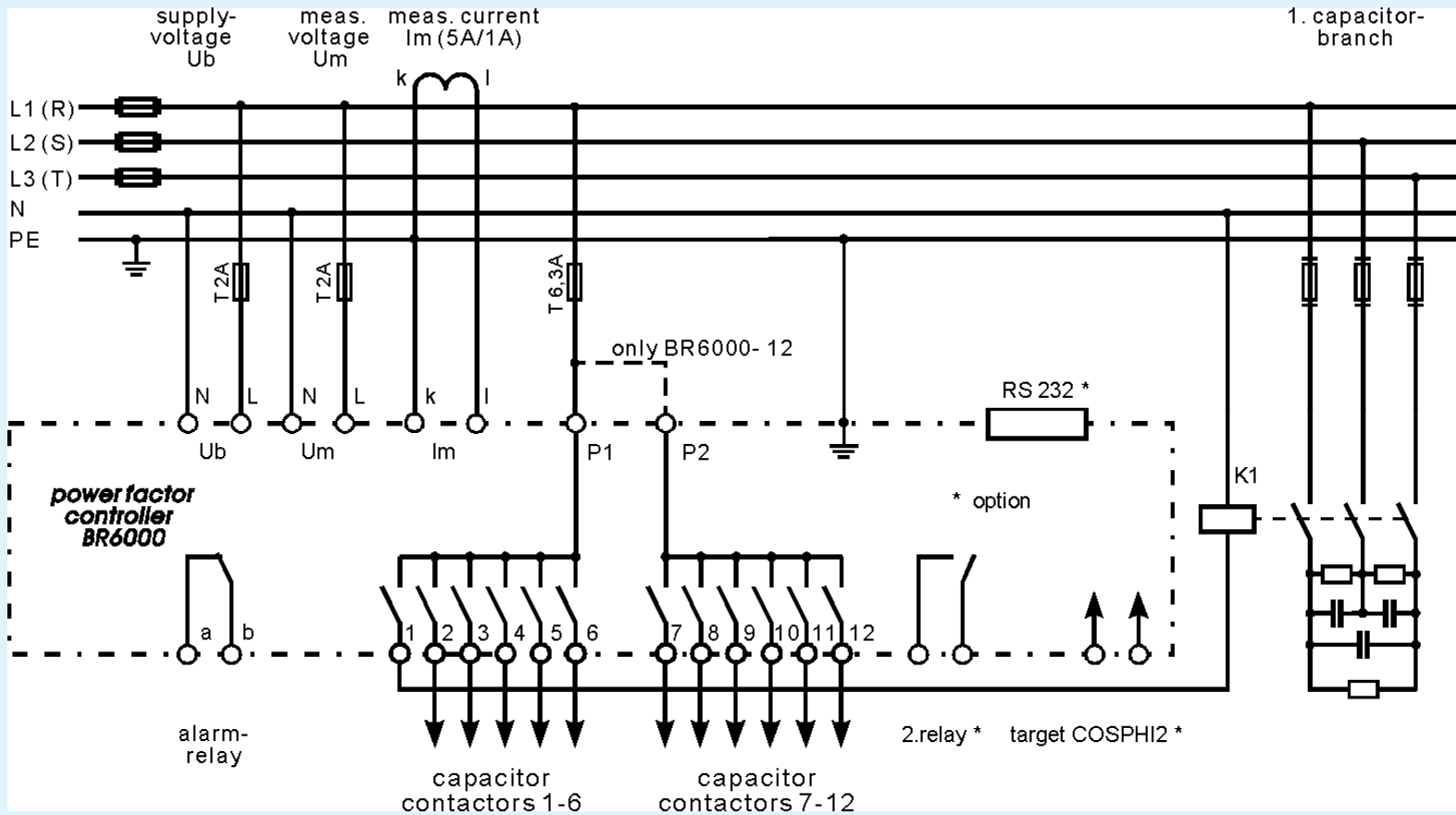

# BR6000 Structured menu dialog

## Clearly structured menu dialog, for easy...

...installation

...operation

...failure analysis

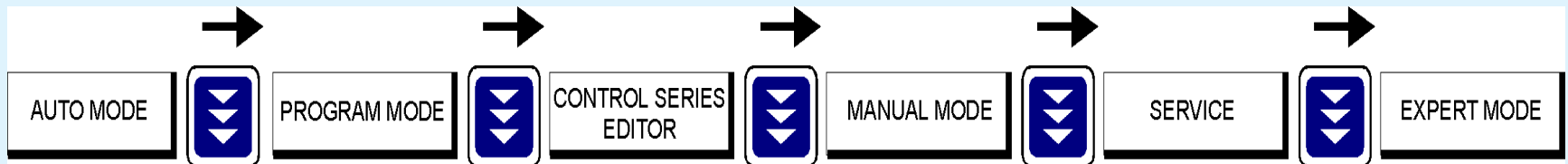

# BR6000 Control diagram

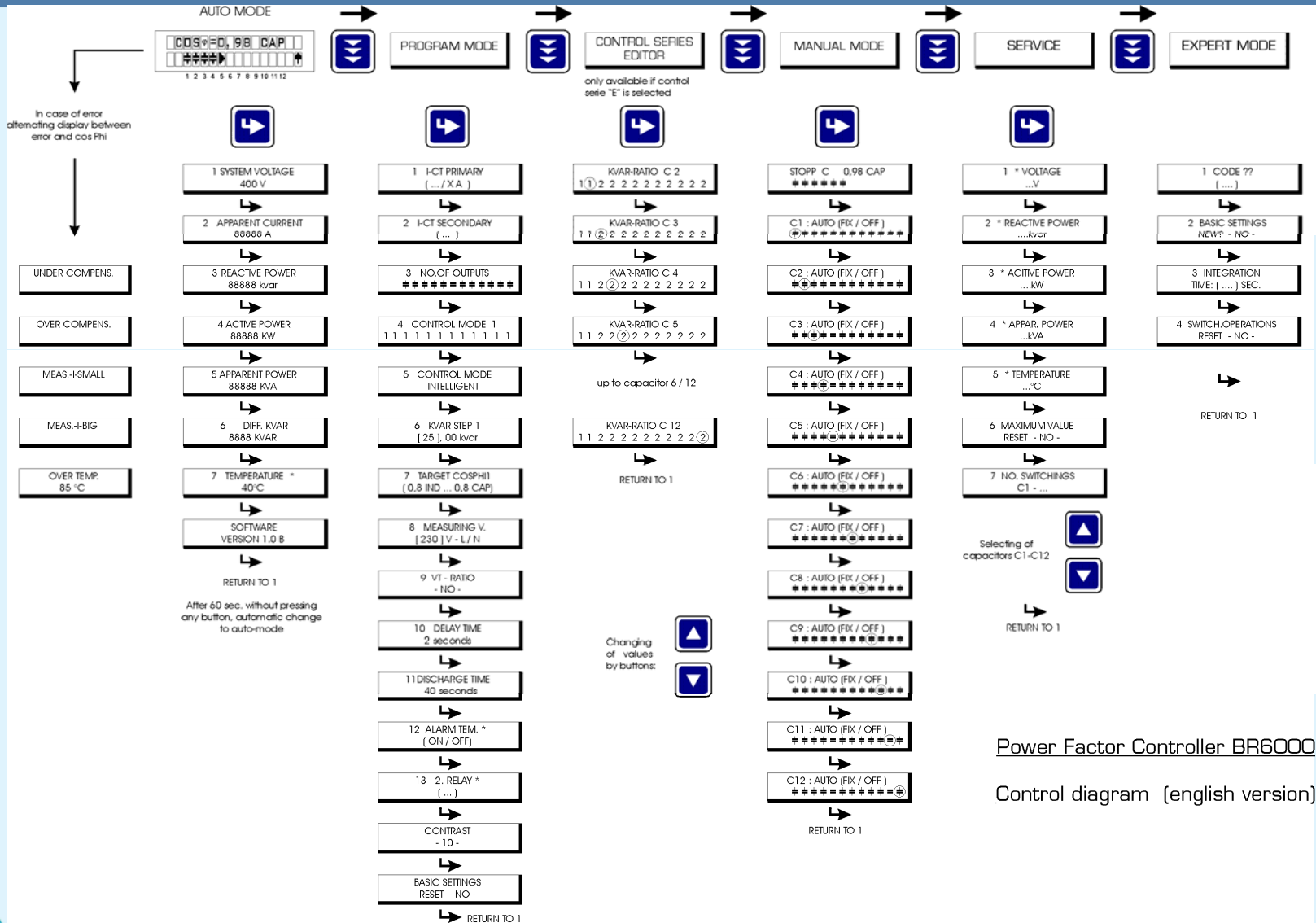

Power Factor Controller BR6000  
Control diagram (english version)

# BR6000 Customer benefits

## Plain language menu:

- User friendly – human machine interface
- Menu and programming in plain language
- Easy understandable terms
- One main menu for programming
- Clearly arranged menu structure
- Local languages can be programmed upon demand

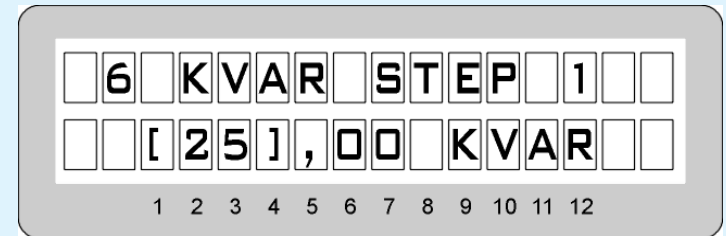

# BR6000 Customer benefits

## Storing of important system parameters

- Max. voltage
- Max. reactive power
- Max. active power
- Max. apparent power
- Max. number of switchings
- Operation time of each capacitor
- Max. temperature
- Max. THD-I / THD-V

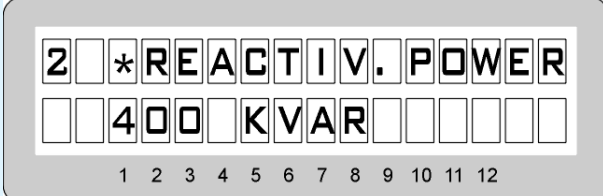

2 \* REACTIV. POWER  
400 KVAR

1 2 3 4 5 6 7 8 9 10 11 12

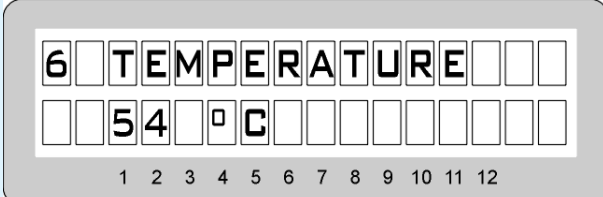

6 TEMPERATURE  
54 °C

1 2 3 4 5 6 7 8 9 10 11 12

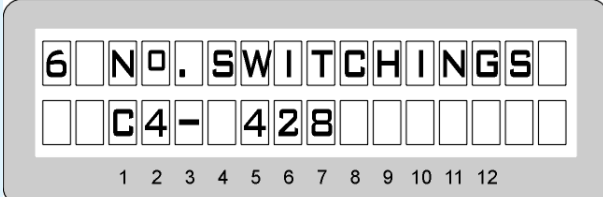

6 NO. SWITCHINGS  
C4-428

1 2 3 4 5 6 7 8 9 10 11 12

# BR6000 Customer benefits

## Three different control modes

1. Serial connection – LIFO
2. Circular mode – FIFO
3. Intelligent mode (factory pre-set)

# BR6000 Customer benefits

## Counter for contactor switchings

- Switching of contactors stored individually per stage
- Valuable for failure tracking
- Recognition of controller hunting
- Replacement of contactors at end of service life

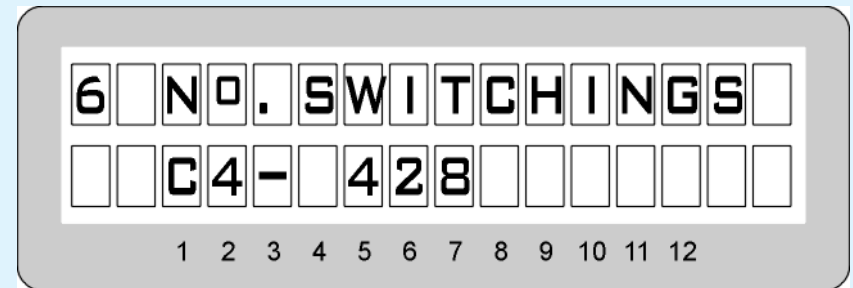

# BR6000 Customer benefits

## Manual operation

- All capacitors can be switched in manually individually
- Individual steps can be programmed as fixed stages
- Easy identification of defect contactors
  - Useful for low load or installation period
  - Useful for maintenance

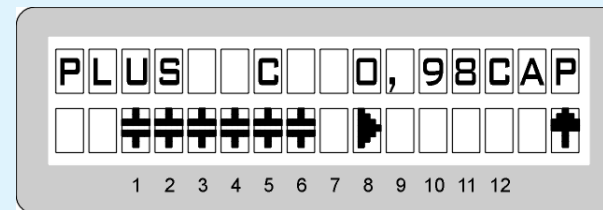
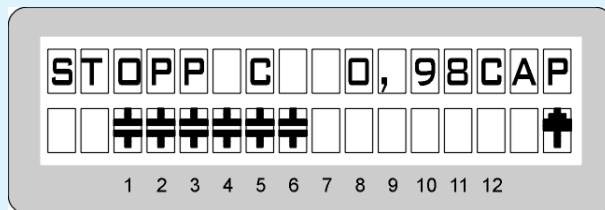

# BR6000 Customer benefits

## Temperature control

Max. temperature stored

- Valuable for failure tracking
  - Over temperature is one of the main reasons for defect capacitors
  - Detects defect cooling systems
  - Detects sporadic over heating

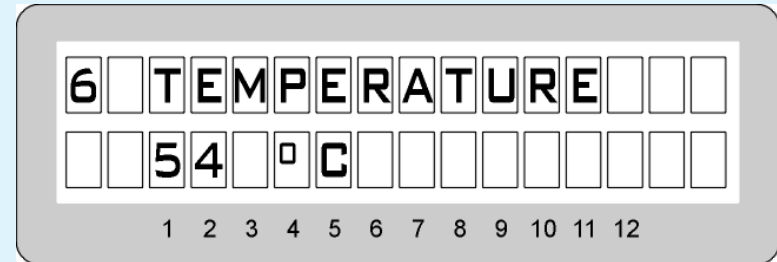

# BR6000 Customer benefits

## Automatic test run

- for automatic testing of all settings
- evaluation of capacitor output
- plausibility clause of settings

### Checking of

- nominal voltage
- nominal current
- phase situation
- current transformer ratio
- control series
- end stop
- capacitor

# BR6000 Customer benefits

## Wide range of operating voltages

- Standard operating voltage is 230V Phase/Neutral
- Optional: 100V, 110V, 440V
- The 100V and 110V versions, even allow to use the controller for high voltage applications!
- Suitable for following grids:  
110, 230, 400, 415, 440, 480 and 525 V

# BR6000 Customer benefits

## Wide range of measuring voltage

- Measuring voltage range: 30...300 V Phase/Neutral
- Suitable for following grids:  
110V, 230V, 400V, 415V, 440V, 480V and 525V
- Phase shift can be programmed individually for each particular application.
- The 100V and 110V versions, even allow to use the controller for high voltage applications!
- The VT ratio can be programmed!



# BR6000 Connection of measuring current and voltage

## Attention!

The operating voltage for the contactors should be taken from a phase connected to the reactive power controller.

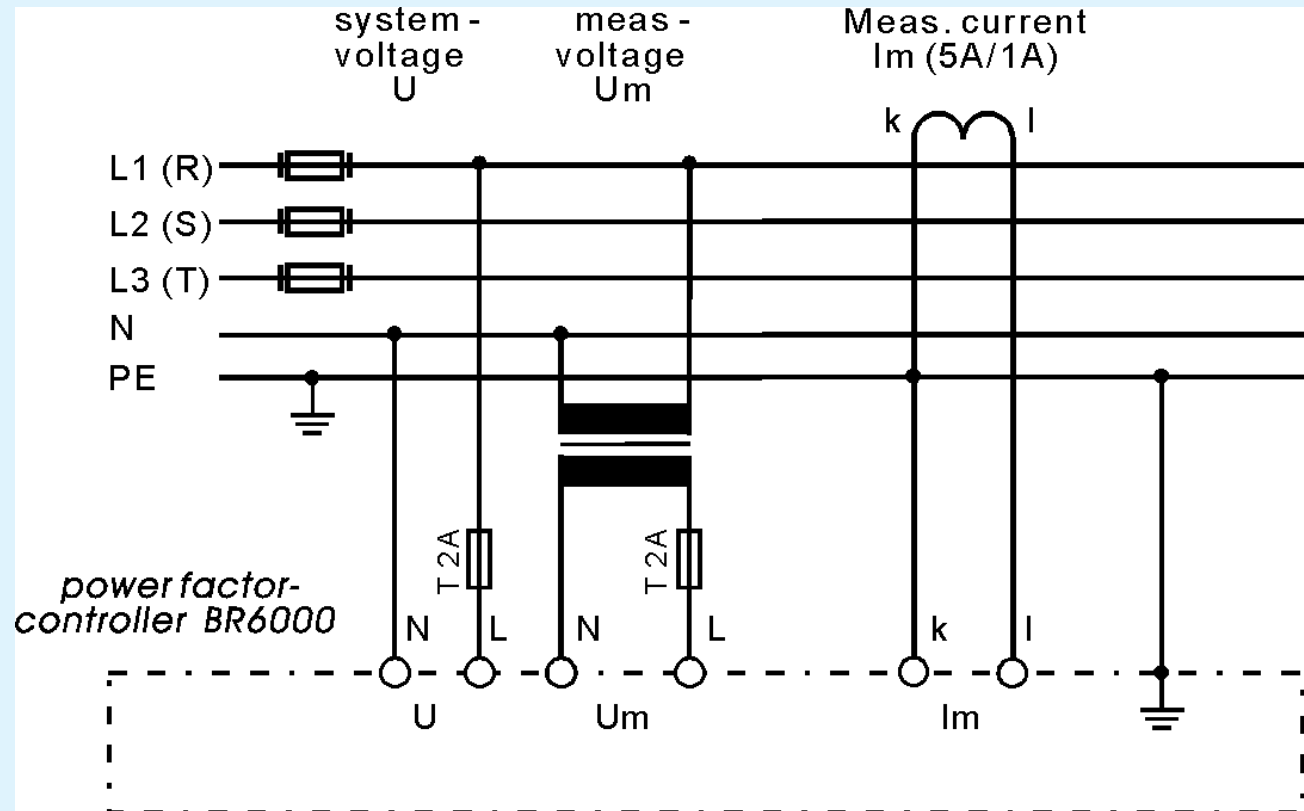

# BR6000 Generator operation

- 4 quadrant operation possible
- Usage for consumption and supply of energy  
(e. g. water power plant with generator operation)

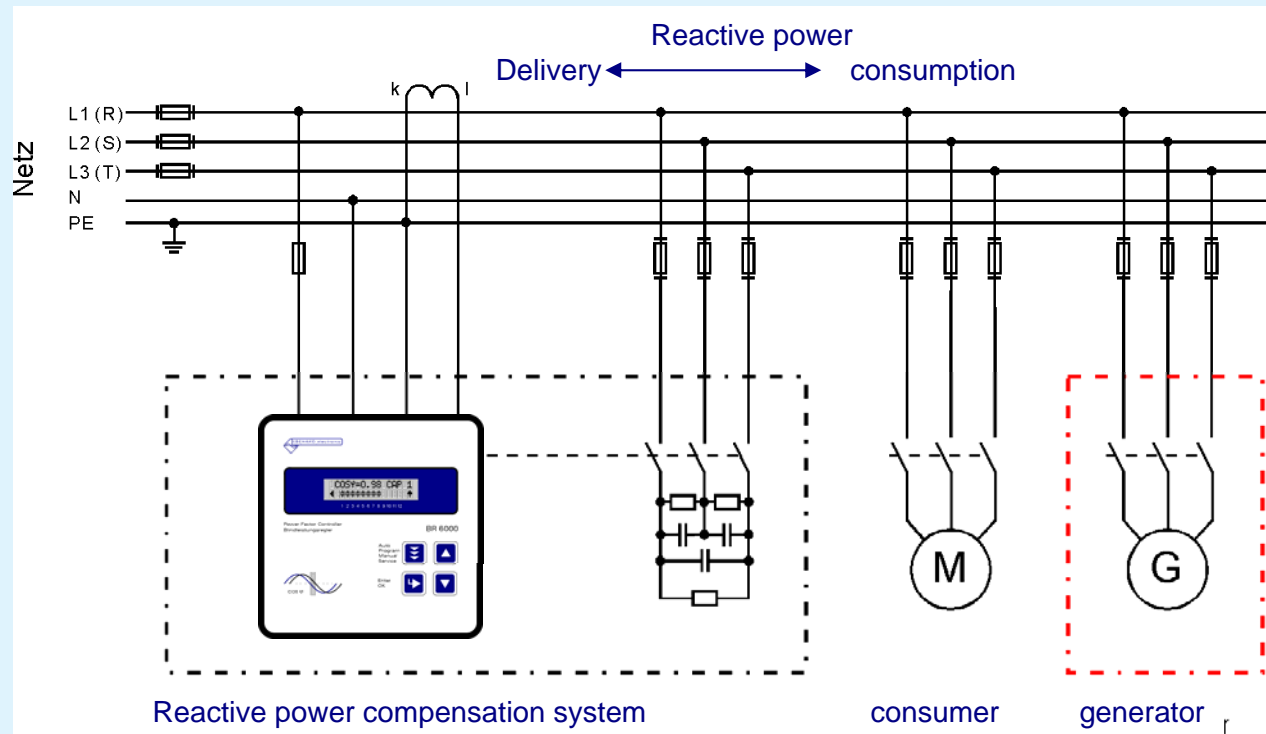

# BR6000 Control series editor

The BR6000 is the very first controller which allows an individual programming of a control series – control series editor. This ensures an optimized adjustment to any existing PFC system.

The programming is menu guided, and intelligent, means only realistic control series can be entered.

# BR6000 Preset control series

Nr.	Control series	Circular switching
1	1 : 1 : 1 : 1 : 1 : 1 : 1 : 1 : 1 : 1 : 1 : 1	Possible
2	1 : 2 : 2 : 2 : 2 : 2 : 2 : 2 : 2 : 2 : 2 : 2	Possible
3	1 : 2 : 3 : 3 : 3 : 3 : 3 : 3 : 3 : 3 : 3 : 3	Possible
4	1 : 2 : 3 : 4 : 4 : 4 : 4 : 4 : 4 : 4 : 4 : 4	Possible
5	1 : 2 : 4 : 4 : 4 : 4 : 4 : 4 : 4 : 4 : 4 : 4	Possible
6	1 : 2 : 3 : 6 : 6 : 6 : 6 : 6 : 6 : 6 : 6 : 6	Possible
7	1 : 2 : 4 : 8 : 8 : 8 : 8 : 8 : 8 : 8 : 8 : 8	Possible
8	1 : 1 : 1 : 1 : 2 : 2 : 2 : 2 : 2 : 2 : 2 : 2	Possible
9	1 : 1 : 1 : 1 : 1 : 6 : 6 : 6 : 6 : 6 : 6 : 6	Possible
10	1 : 1 : 2 : 2 : 2 : 2 : 2 : 2 : 2 : 2 : 2 : 2	Possible
11	1 : 1 : 2 : 2 : 2 : 4 : 4 : 4 : 4 : 4 : 4 : 4	Possible
12	1 : 1 : 2 : 2 : 4 : 4 : 4 : 4 : 4 : 4 : 4 : 4	Possible
13	1 : 1 : 1 : 2 : 2 : 2 : 2 : 2 : 2 : 2 : 2 : 2	Possible
14	1 : 1 : 2 : 3 : 3 : 3 : 3 : 3 : 3 : 3 : 3 : 3	Possible
15	1 : 1 : 2 : 4 : 4 : 4 : 4 : 4 : 4 : 4 : 4 : 4	Possible
16	1 : 1 : 2 : 4 : 8 : 8 : 8 : 8 : 8 : 8 : 8 : 8	Possible
17	1 : 2 : 2 : 3 : 3 : 3 : 3 : 3 : 3 : 3 : 3 : 3	Possible
18	1 : 2 : 3 : 4 : 4 : 8 : 8 : 8 : 8 : 8 : 8 : 8	Possible
19	1 : 2 : 2 : 4 : 4 : 4 : 4 : 4 : 4 : 4 : 4 : 4	Possible
20	1 : 2 : 2 : 2 : 4 : 4 : 4 : 4 : 4 : 4 : 4 : 4	Possible
„E“	Editor	Possible

# BR6000 Interface option

## Interface RS232 or RS485

⇒ **Interface RS 232** (Windows-Software included):

- Setting parameter via PC interface
- Reading out of operation status
- Connection of remote display for all measured values

⇒ **Interface RS 485:**

- Interconnection with other controllers or control- / display units
- MODBUS or ASCII Protocol

# BR6000-R12/S232

## Windows Software

BR6000 with RS232 interface:

comfortable visualization  
software (Windows) in  
the extend of delivery



# BR6000 Applications

## Dynamic PFC

Target Applications:

- Welding / spot welding equipment
- Presses (e.g. most car factories in Germany use meanwhile dynamic PFC)
- Wind turbine generators
- Container cranes
- Lifts
- Central motor start up compensation
- Any fast fluctuating load requires **DYNAMIC** PFC



# BR6000 Applications

## BR6000 for Dynamic PFC (transistor output)

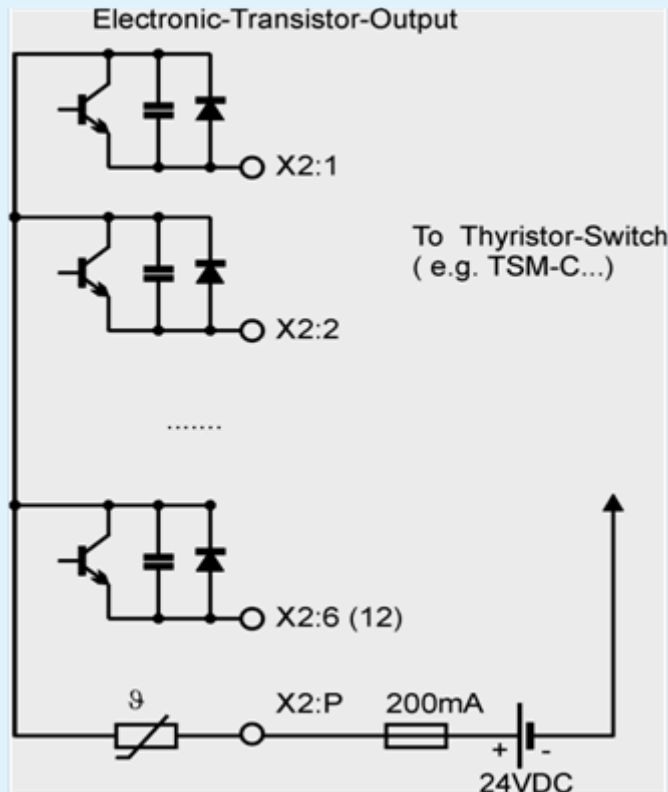

Thyristor-switch „TSM-LC“

# BR6000 for dynamic PFC

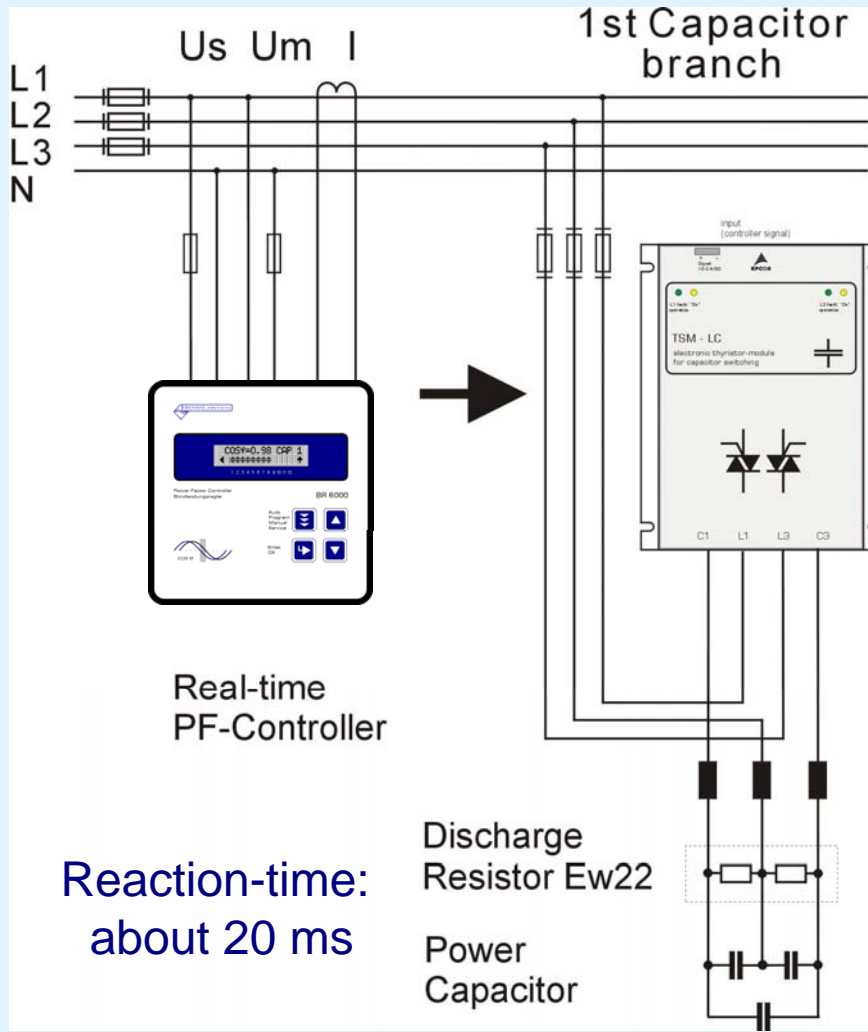

TSM-LC



# BR6000 Application

## Sum current transformer

Connecting BR6000 via a sum current transformer, the total transformation ratio has to be programmed:

$$(1000 + 1000) / 1 = 2000$$

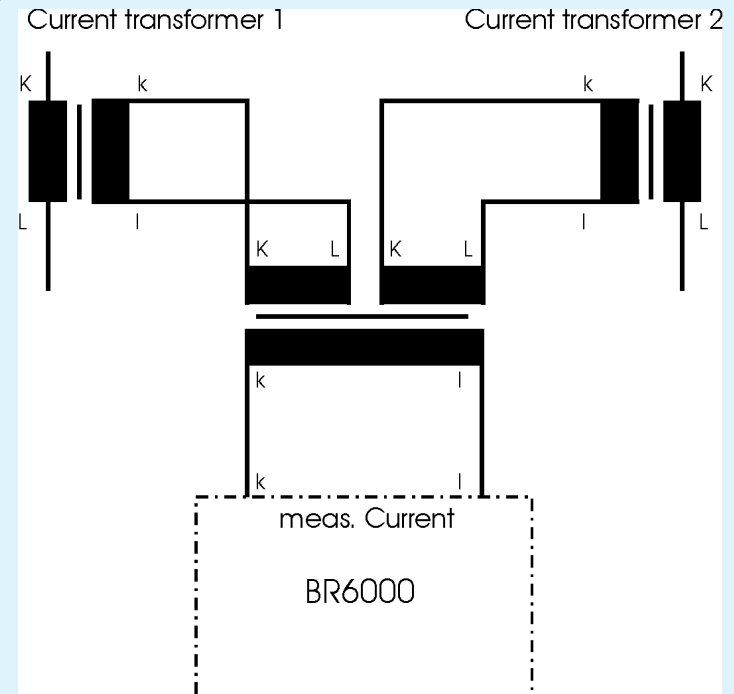

# BR6000 Technical data (1)

Outputs:	6 and 12
Switching power of relay:	250VAC, 1000W
Number of outputs:	programmable
Display:	graphic display 2 x 16 characters
Number of control series:	20 (plus editor)
Control principle:	sequential-, loop connection, self optimized switching response
Supply voltage:	230 VAC (standard) 50/60 Hz
Measuring voltage:	30 ... 300 VAC 50/60 Hz
Measuring current:	X : 5/1 A
Sensitivity:	50 mA / 10 mA
Target cos Phi:	0.8 ind. to 0.8 cap.



# BR6000 Technical data (2)

Connecting time:	selectable from 1...255 sec.
Disconnecting time:	selectable from 1...255 sec.
Discharge time:	selectable from 1...255 sec.
Fixed stages / skipped stages:	programmable
No-voltage trigger:	standard
Display of grid parameters:	PF, V, I, Q, P, S, F, Temp.
Storage of maximum values:	V, Q, P, S, Tem, THD-V/THD-I
Housing:	switchboard integrated
Dimensions:	144 x 144 x 60mm
Weight:	1 kg
Operating temperature:	-10 to +60 °C
Protection type to DIN 40 050:	front IP 54 rear IP 20

# BR6000 Variants

<b>BR 6000-R06</b>	6 Relay outputs / alarm relay
<b>BR 6000-R12</b>	12 Relay outputs / alarm relay
<b>BR 6000-T06</b>	6 Transistor outputs / alarm relay (for RTPFC)
<b>BR 6000-T12</b>	12 Transistor outputs / alarm relay (for RTPFC)
<b>Option /F</b>	2 <sup>nd</sup> message relays, input for 2 <sup>nd</sup> target PF
<b>Option /S ...</b>	same as Option /F, additional RS232 or RS485 interface (options only for 12 step controller)

Power Factor Correction



# BR6000

## Controller for PFC

### Customer benefits

- 6 and 12 step version available
- Innovative design and economical pricing
- Most user-friendly controller, easiest installation, operation and servicing
- Illuminated graphic display, 2 x 16 characters
- Human machine interface by plain language menu
- Intelligent control with self-optimizing control behavior
- World's first control series editor, allows individual programming of the kvar ratios
- Memory for various parameters:
  - Number of switching operation for each contactor
  - Max. voltage
  - Max. temperature
  - Max. active power
  - Max. reactive power
- Powerful alarm output:
  - Missing compensation output
  - Over temperature
  - Under current
- THD-V, THD-I, individual harmonics up to 19<sup>th</sup>
- Optional available:
  - Real time power factor correction control (Thyristor switches)
  - RS232/RS485 interface

More information at [www.epcos.com/pfc](http://www.epcos.com/pfc)

just everywhere ...